



CRD- SERIES PROGRAMMABLE SETPOINT RELAY

Operation Guide



Valid for models CRD-005 and CRD-020
to be used in conjunction with standard
CRD model product specification sheet.

Use of this manual by qualified electrical personnel.

Ohio Semitronics, Inc.
4242 Reynolds Dr.
Hilliard Oh. 43026
1-800-537-6732
www.ohiosemitronics.com
By: Cory Forler

8/26/2014 Rev --

The CRD series is designed to monitor an electrical input value with a Form C relay output that changes states at a selected percentage level of the input. The CRD series relay is a protection device operating in a Fail Safe mode during normal monitoring conditions. The relay changes states to alarm when the input surpasses a predetermined point of input. Alternatively the user can set the alarm state to activate when the input drops below a predetermined input setpoint level.

FAIL-SAFE: Causing a piece of machinery or other mechanism to revert to a safe condition in the event of a breakdown or malfunction (causing no harm to humans).

INPUTS:

Model CRD-020 input ranges are 5Aac, 10Aac, 15Aac or 20Aac selectable.

Model CRD-005 input ranges are 1mAdc or 10Vdc selectable.

SETPOINT:

The CRD input can be set by the user to alarm anywhere over the selected input range between 1 to 99%. A push button selector digital switch is located on top of the CRD to set the desired threshold level as a percent of input range that is shown on the switch.

TWO OPERATING MODES:

Over Range: Normal input monitoring operation with alarm state of change occurring when the input exceeds the setpoint (percentage). Red LED light is on in alarm condition. Alarm state of change will also occur if the CRD loses 120Vac instrument power at terminals 6 & 6A.

Under Range: Normal input monitoring operation with alarm state of change occurring when the input drops below the setpoint (percentage). Red LED light is on in alarm condition. Alarm state of change will also occur if the CRD loses 120Vac instrument power at terminals 6 & 6A.

Note: Red LED will not stay lit with loss of instrument power, however it is also considered to be in the alarm relay de-energized state.

OUTPUT (FORM C RELAY):

The action of the CRD form C relay coincides with several terminologies and some are interchangeable: Energize, De-energize, Threshold Level, Alarm, Setpoint, Trip-point, Switch, Change-of-state, Activate, Open, Close. (N/O = Normally Open. N/C = Normally Closed).

Figure 1 depicts a single line diagram example of monitoring the input current from a single leg of a AC motor. The CRD is set to alarm (De-energize) at an abnormally high motor current (Over Range Mode). The CRD output relay activates an external feedback circuit that causes the motor to shut down.

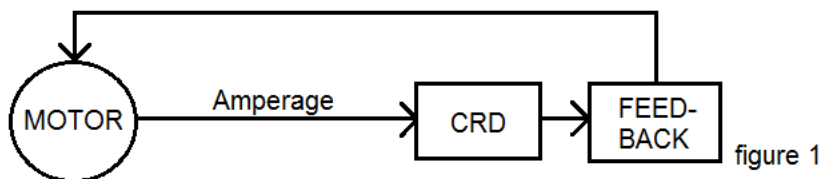

The same CRD shown above can be configured to the Under Range Mode to alarm (De-energize) if the motor current drops to an abnormally low level. The feedback circuit could theoretically be removed and replaced with a warning siren that alerts workers of a deficiency in motor output.

ELECTRICAL CONNECTIONS:

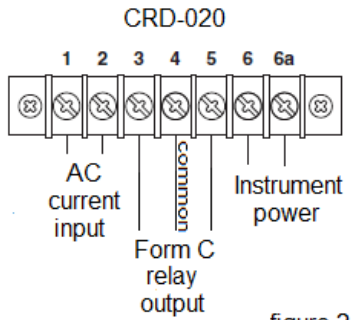

figure 2

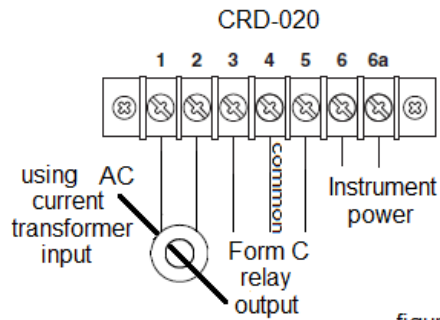

figure 3

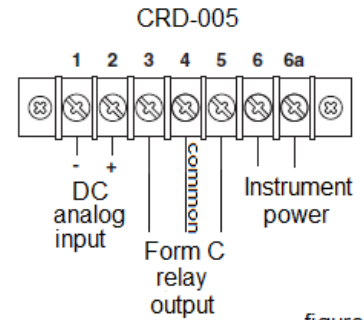

figure 4

CRD-020 with AC current of up to 20Aac can be wired directly to the input (figure 2).

CRD-020 with a current transformer (CT) can be connected to the input to monitor and step down a high current value that has a typical secondary rating of 5Aac. Percent of input setpoint is now based on the CT primary value (figure 3).

CRD-020 input is not input polarity sensitive and factory default set to 5Aac & **Over Range Mode**.

CRD-020 Input Burden on external circuits is rated at 0.5VA max for all range settings.

CRD-005 is DC input polarity sensitive with terminal 1 being negative and terminal 2 being positive (figure 4).

CRD-005 is factory default set to 1mAdc & **Over Range Mode**.

CRD-005 Input Burden on external circuits is 1kΩ for 1mAdc setting and 10kΩ for 10Vdc setting.

CRD-020 & CRD-005:

Terminal 4 is an isolated common Form C relay output connection.

Standard instrument power is rated at 85-135Vac at 6 & 6A.

Special instrument power inputs are available. See page 6.

7 position terminal strip is rated to 300V using # 6-32 screws at 0.375" centers/spacing.

A CLOSER LOOK AT THE COMPONENTS/OPERATION AND USER SETTINGS:

Form C relay: Rated for an external circuit up to 120Vac potential and maximum current of up to 3 amps.
It is typical to utilize only 2 of the 3 terminals of the output relay to complete the user external circuit.

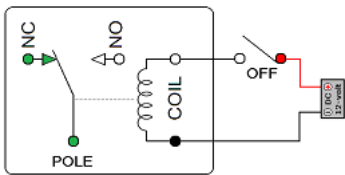

De-energized (Alarm condition).
CRD Terminal 3 is NC.
CRD Terminal 4 is Pole (common).
CRD Terminal 5 is NO.

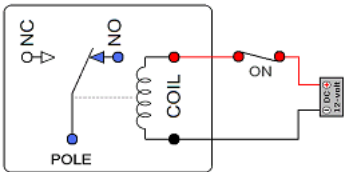

Energized relay state when relay coil activated (normal operation/“fail safe” mode).

←Note: On/Off Switch and 12Vdc supply are shown for demonstration purposes and do not reflect the actual CRD circuit.

Digital SPDT Switch:

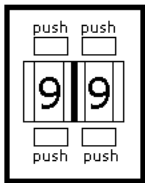

Pushbutton decade switch allows the user to set the level of input where the relay de-energizes. Located top of lid, displayed as a percentage of input.

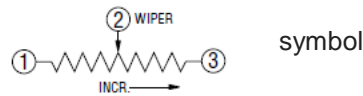

Fine Adjust Potentiometer:

Located through an access hole in the top lid, the user can fine tune the alarm setpoint (de-energize).

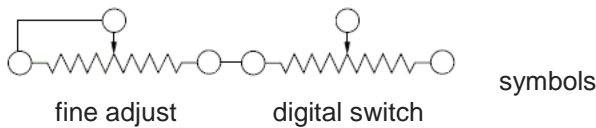

8 position DIP SPST switch:

Located inside the unit this switch is user accessible and provides options to set the input range along with the operating modes for “under” or “over” range alarming.

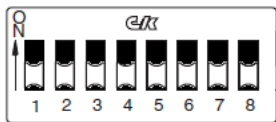

Notes:

- SPDT: Single Pole Double Throw.
- SPST: Single Pole Single Throw.
- DIP: Dual In-Line Package.

REMOVING THE CRD FROM THE ENCLOSURE:

The factory settings for CRD-020 are 5Aac input & Over-Range mode & no requirement to remove from enclosure. The factory settings for CRD-005 are 1mAdc input and Over-Range mode & no requirement to remove/enclosure. All other settings require removal of unit (see product specification sheet for all optional settings).

When removing unit from enclosure turn off all input power.

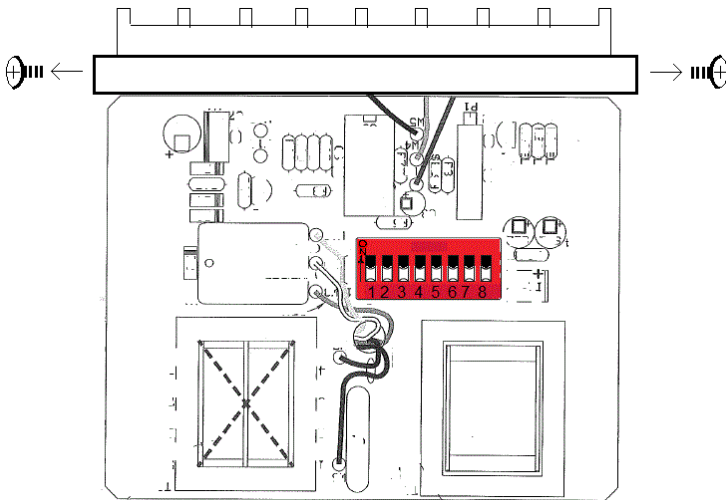

Cut a slit in the silver “seal” under the lip of the CRD lid. Breaking this seal will not affect the CRD’s 5 year warranty.

Remove side screws and lift straight up.

Adjust DIP switch (red) to desired settings. **Do not power up or operate CRD outside of the enclosure.**

Reinstall unit in enclosure and attach side-screws.

Unit is now ready for power/input.

figure 5

ALL POSSIBLE DIP SPST INTERNAL SWITCH SETTINGS:

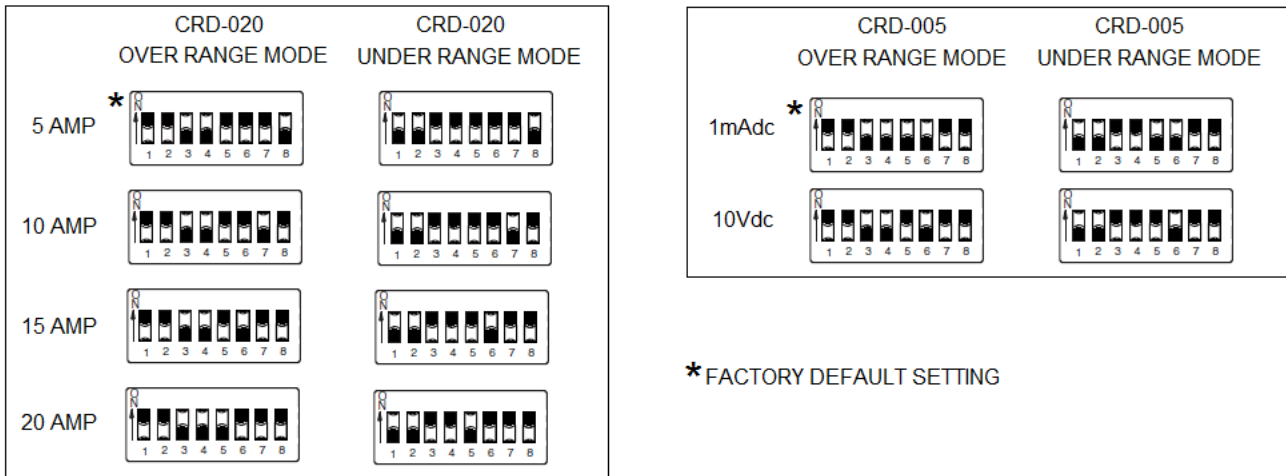

figure 6

RELAY SEQUENCING AND THE DIFFERENCE BETWEEN THE TWO OPERATING MODES:

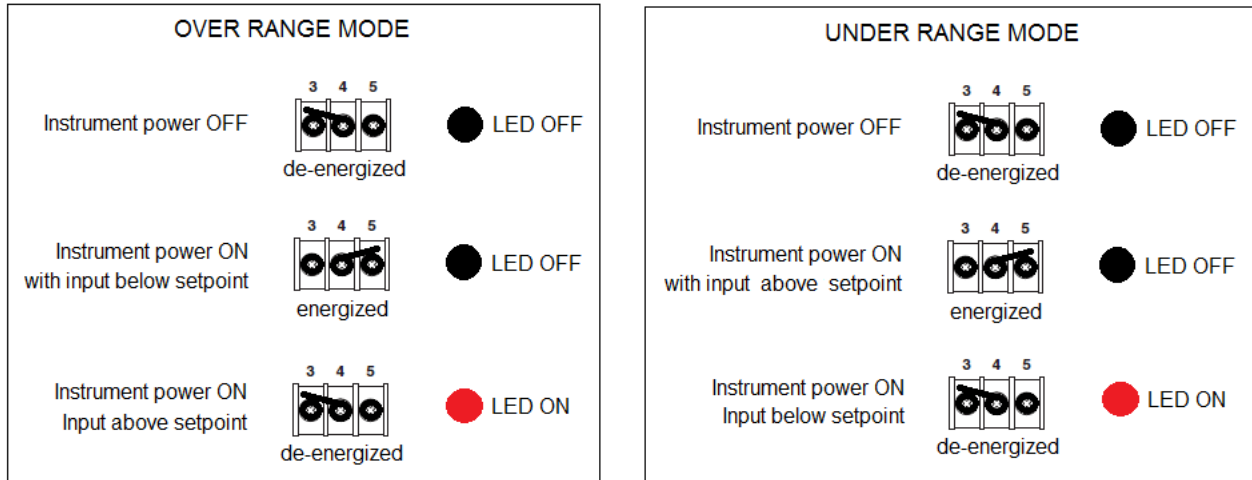
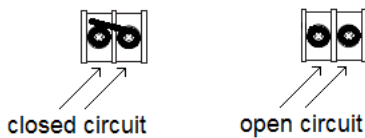

figure 7

Note concerning figure 7:



NON CATALOG MODEL OPTIONS AVAILABLE:

CRD-020Y01 & CRD-005Y01
220Vac instrument power ($\pm 10\%$).

CRD-020Y18 & CRD-005Y18
24Vdc instrument power (terminal 6+ and terminal 6A-).

CRD-005Y21
4-20mAdc input.

CRD-020Y22 & CRD-005Y22
Terminal guard safety covers added.